

# **The Future of Swiss Hydropower: Distributional Effects of Water Fee Reform Options**

Interim Project Report, September 2018

Regina Betz<sup>(a)</sup>, Thomas Geissmann<sup>(a)</sup>, Werner Hediger<sup>(b)</sup>, Marc Herter<sup>(b)</sup>,  
Moritz Schillinger<sup>(c)</sup>, Christoph Schuler<sup>(d)</sup>, Hannes Weigt<sup>(c)</sup>

(a) Center for Energy and the Environment (CEE), ZHAW, Winterthur, Switzerland

(b) Zentrum für wirtschaftspolitische Forschung, HTW Chur, Chur, Switzerland

(c) Forschungsstelle Nachhaltige Energie- und Wasserversorgung, University of Basel, Basel, Switzerland

(d) Institute of Public Management, ZHAW, Winterthur, Switzerland

## Corresponding author:

Hannes Weigt  
Forschungsstelle Nachhaltige Energie- und Wasserversorgung  
Wirtschaftswissenschaftliche Fakultät der Universität Basel  
Peter Merian-Weg 6, Postfach, CH-4002 Basel  
Tel: +41 (0)61 207 3259  
Mail: hannes.weigt@unibas.ch

The NRP70 project ‘The Future of Swiss Hydropower: An Integrated Economic Assessment of Chances, Threats and Solutions’ (HP Future) addresses the challenges Swiss Hydropower faces in the changing electricity market environment. In particular it aims to answer three main research questions:

1. What are *short-term operational* options for Swiss HP to cope with the volatile market situation?
2. What are *long-term investment* options for Swiss HP and how can *uncertainty* be accounted?
3. What are the *regional impacts* from a comprehensive *sustainability perspective*?

The project started in fall 2014. During the project the discussion on adjustments of the Swiss water fee framework emerged, leading to an extension of the project:

4. What are the *distributional effects* of different *water fee* reform options?
5. What are regional, fiscal and economic *feedback effects* of those changes?

This interim report provides a summary on the main findings to question 4, so far.

## **Acknowledgements:**

This research is undertaken within the frame of the National Research Programme “Energy Turnaround” (NRP 70) of the Swiss National Science Foundation (SNSF). Further information on the National Research Programme can be found at [www.nrp70.ch](http://www.nrp70.ch).



**Energy Turnaround**  
National Research Programme

# 1 Introduction

Water fees are a remuneration to be paid by the operators of hydropower plants to the owners of the water resource right. According to federal legislation (Art. 76 IV of the Swiss Federal Constitution and Art. 2 I of the Water Rights Act, WRG), this right is with the cantons and can entirely or in parts be transferred to other communities, such as municipalities, districts and cooperatives. The Confederation has the right to determine the maximum water fee level (Art. 49 I WRG). Currently, the fee is based on the gross capacity of the plant and estimated using the gradient and the amount of water that can be used for electricity generation depending on the hydrological conditions as defined in the concession. It is thus not based on economic but on physical principles. Besides the earnings from water fees, cantons where hydropower plants are situated receive proceeds from taxes on income and property. The majority of this tax revenue flows to cantons, a smaller share to municipalities. In addition, the cantons may receive dividends when holding the shares of the hydropower utilities and profit taxes. Some of the latter may also generate revenue to the federal government.

The water fee level has been adjusted several times since the introduction in 1918. It started at a level of 6 CHF/PS (around 8.16 CHF/kW) and the last increase was in two steps from 80 CHF/kW to 100 CHF/kW and 110 CHF/kW in January 2011 and 2015, respectively. Launched in 2008 by a parliamentary initiative, the last increase was justified with higher peak and balancing electricity prices, the higher value of energy storage as well as the compensation for inflation (Bundesrat, 2018a). However, soon after the increase of the water fee maximum the situation changed and the electricity wholesale market prices and corresponding profits of hydropower plants were falling. The economic crisis, the low prices of coal and CO<sub>2</sub> certificates as well as subsidies for renewable energies in European countries, that also reduced the spread between peak and off-peak prices, have led to a significant drop in overall electricity wholesale market prices: Peak prices dropped from 152 CHF/MWh in 2008 to 44.79 CHF/MWh in 2016 and the spread from 34 CHF/MWh to 3.5 CHF/MWh (Bundesrat 2018a). Therefore, the profitability of hydropower plants got under pressure. Given that the profits of the plant owners depend on current market prices and electricity generation, there is a disconnect between the variable profits of hydropower plant owners and fixed water fees. Given those developments and the legal requirement to review the water fee levels in 2019 (now postponed to 2024), the discussion of a reform of the system of water levies is ongoing.

The aim of this sub-project is to analyse the distributional consequences of different reform options on cantonal and municipality level. This involves an in-depth assessment of the profits of hydropower plants in the recent past and under the assumption of different reform options and future price scenarios. In addition, an analysis of the monetary flows of the national fiscal equalisation system and the distribution of water fees between the cantons is provided. In order to gain a full picture of attributable financial flows between cantons, their ownership in utilities needs to be assessed. Finally, the analysis includes the distributional effects within cantons, where municipalities receive revenues from water fees and where the water fees are included in the cantonal system of fiscal equalization.

## 2 Production costs of Swiss hydropower companies in 2015/16

In order to determine the profitability of Swiss hydropower plants, costs and revenues must be estimated. The costs are derived for a balanced panel *data set of 62 hydropower companies* for the years 2015 and 2016. Most of these companies are so-called “Partnerwerke”, which means that different utilities are jointly holding the concession for a hydropower plant. Based on the annual reports, income statements, and balance sheets, financial information is gathered and combined with the amount of electricity generated, the pump energy consumed, and the accumulated installed generator power, as provided by the Swiss Federal Office of Energy (SFOE) in the statistics of hydropower plants in Switzerland (WASTA).

Following Filippini and Geissmann (2018), hydropower companies are classified into three distinctive technical categories reflecting the predominant technology of the stations operated by a company<sup>1</sup> resulting in the following number of types covered by our sample: 36 run-of-river companies, 12 storage companies, and 14 pump-storage companies. Although only around 25 % of the hydropower plants listed in WASTA belong to the 62 companies surveyed, this sample represents around 86 % of the total expected storage production, 76 % of the expected pump-storage production and around 44 % of the expected run-of-river production in 2016.

In general, the calculation of the production costs of hydropower company can be estimated from a financial and imputed costs perspective. For our analysis we are using both, with the imputed costs perspective being based on exogenous values of the interest and return on equity as proposed by Filippini and Geissmann (2018). For the imputed costs, a weighted average cost of capital (WACC) of 5 % is assumed (see Filippini and Geissmann (2018) for a description of the derivation of this number). Results using imputed costs are listed in the appendix.

While the *average costs levels* based on a financial cost accounting is *about 53 CHF/MWh*, the *costs structure of the three company types varies significantly*, with companies classified as pump-storage showing significant higher cost levels (see figure on next page). Three main underlying factors can be identified: Firstly, pump-storage plants are more capital intensive than the other technologies because their technological complexity is higher. Secondly, they incur higher operating costs due the electricity consumption to pump water at times of low prices. Thirdly, several large and expensive construction projects were undertaken in recent years to expand the pump-storage capacity in Switzerland, which increases capital costs of this technology.

The *share of the water fee* of the total production costs varies with the type of the plant but is on *average 23% or 12.4 CHF/MWh* .

---

<sup>1</sup> A company is categorized as run-of-river if at least 50% of the expected yearly generation stems from run-of-river stations. Analogously, a company is of type storage if at least 50% of the expected electricity generation is generated by storage units, whereby the share of the installed pumping capacity has to be less or equal to 5% of the total installed turbine capacity. Consequently, a company is of type pump-storage if at least 50% of the expected electricity generation is generated by storage units, whereby the share of the installed pumping capacity is higher than 5% of the installed turbine capacity.

## Production costs 2015/16 using financial cost accounting

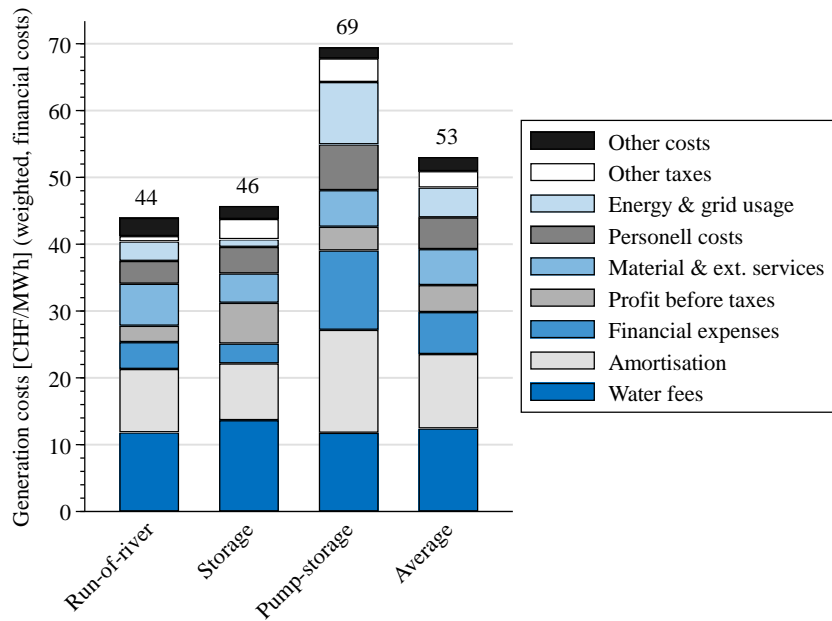

Note: These cost estimates have some limitations; i.e. they do not take into account the costs incurred by parent companies for coordinating and marketing the electricity generated since they are not listed in the business reports of a partner company.

The average production costs of the 62 hydropower companies can be ordered to derive a *pseudo merit order* (see Figure below) that provides a step-by-step supply curve as a function of the cumulative installed capacity (left side) as well as the mean gross production shown in the financial accounting annual reports (right side).

## Production costs 2015/16 using financial cost accounting

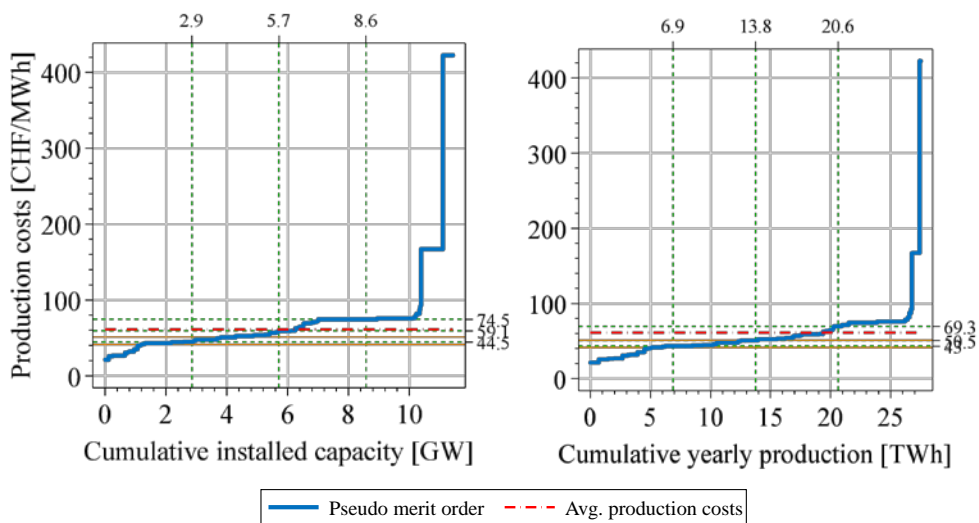

Note: The pseudo merit order summarizes the average production costs of all 62 hydropower companies for the years 2015 and 2016 (adjusted for inflation based on 2015). The green dashed lines represent the 25, 50, and 75 percent percentile. The orange solid lines represent the base and peak load price of 2015 (Bundesrat 2018), respectively.

For the investigated company sample the median production cost levels is 53.2 CHF/MWh with 50 % of total installed capacity showing costs between 44.5 and 74.5 CHF/MWh in 2015/2016 (left side). 25 % of the installed capacity, namely 2.86 GW, can generate their electricity at production costs of less than 44.5 CHF/MWh. The situation is similar if the average production costs are ordered as a function of the annual production (right side): Around 13.76 TWh can be generated at a cost between 43 and 69.3 CHF/MWh with about 6.88 TWh having a production costs level of less than 43.0 CHF/MWh.

When comparing the capacity and production based cost structures, it can also be seen that a slightly higher percentage of electricity can be generated at relatively low cost (the 25 cost percentile for the production is 43 CHF/MWh, while it is 44.5 CHF/MWh for the installed capacity). The reason for this is that run-of-river plants have a relatively high capacity factor with at the same time relatively low production costs.

Summarizing, the cost assessment for the company sample highlights the *heterogeneity of Swiss hydropower*. If we compare these cost figures with the Swiss average prices (orange lines: base price of 43 CHF/MWh and peak price of 51 CHF/MWh in 2015, Bundesrat 2018a) it becomes obvious that more than half of the companies in our sample show higher costs levels.

### **3 How profitable were Swiss hydropower companies in 2015?**

In the next step the cost assessments are compared to the revenues the companies could earn. As the electricity market in Switzerland is only partially liberalized revenues consist of two parts: a) revenues from selling electricity on the free market, and b) revenues from sales to captive customers.

For the *market revenue* estimates, we rely on simulation runs with Swissmod—a Swiss and Central European electricity market model developed at the University Basel. Swissmod includes about 400 hydropower stations (ca. 96% of Swiss hydropower production) and reproduces the dynamics of the day-ahead spot market. Consequently, the market revenues do not include additional revenue options from future, intra-day or system service markets. Regarding the *revenue from captive customers*, we assume that the tariffs are based on the underlying generation cost level; the revenues consist of the unit cost of the electricity production (including costs of equity) multiplied with the amount of electricity sold to captive customers.

Using those estimates, our first assessment for 2015 shows that most companies of the sample are precited to have made losses (see figure on next page). While the use of imputed costs assessments does not alter the general picture (see Appendix), it aggravates the situation of negative profitability, indicating that the companies of the sample on average could not maintain a WACC of 5 %.

Pump-storage companies show the highest variation in estimated profits (beside the low price spread on the market, the higher capital costs of pump-storage stations aggravate the issue of negative profitability), while many run of river companies are close to breaking even. Companies with large

shares of storage plants show a higher profitability, which is a result of the flexibility provided by the water reservoir.

**Profits in million CHF in 2015 using a financial cost accounting**

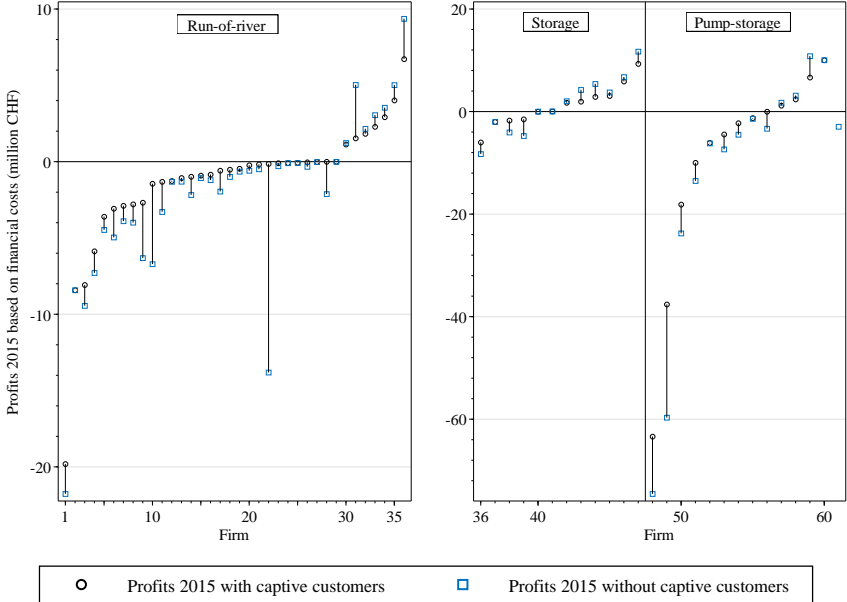

Note: These profit estimates are on company level (Partnerwerke level) and follow the same clustering as presented for the cost assessment.

Summarizing, the results of the profitability assessments are in line with the comparison of costs levels and average EEX market prices: *many companies in our sample show higher costs levels than could be recaptured by energy trading in 2015* (not including additional market options). The results also show that, in general, the role of *captive customers* is rather minor but highly *relevant for specific companies*; again highlighting the heterogeneity of Swiss hydropower.

**4 Revenue prospects for the next decade**

Following the 2015 assessment, the future profitability of Swiss hydropower is analyzed for the years 2020, 2025 and 2030, respectively, to identify whether the challenging income situation could prevail. To this regard, we use Swissmod to derive *four scenarios for future electricity price expectations*, based on different fuel and carbon price developments:

Scenario	Fuel and carbon price development
Base 2015	Fuel and carbon prices as in 2015
EU Trends	Fuel and carbon prices as in EU Reference Scenario (European Commission, 2016)
C++F++	Fast linear increase in carbon price (50€/t in 2030) and fuel prices (+100% until 2030)
C--F--	Linear decrease in carbon price (4€/t in 2030) and fuel prices (-50% until 2030)

The scenarios are meant to capture a range of possible market developments and are not to be seen as a forecast of the most likely developments. The underlying demand and power plant portfolio (capacities in Switzerland and neighboring countries) are taken from the EU Reference Scenario (European Commission, 2016). Furthermore, the four price scenarios are based on real 2015 values (i.e. without inflation or changes in exchange rate) and the assumption of a completely liberalized market. Thus, it is not distinguished anymore if, and to what degree, a company distributes electricity to captive customers. Consequently, the resulting price patterns and revenue estimates provide an indication of market income potentials for Swiss hydropower companies, but are not meant to capture all market and trading possibilities (i.e. future and intra-day trading, system services, special end-user tariffs for green/local production, etc.).

The resulting price pathways (see figure below) show a rather steady or even declining trend for 2020 but large diversions in the years after; leading to a difference of about 60€/MWh between the low and high fuel price assumptions in 2025 and 100€/MWh in 2030. This highlights the **resulting large variability in price levels** and the high dependency of the European market prices on the general drivers (fuel and carbon prices).

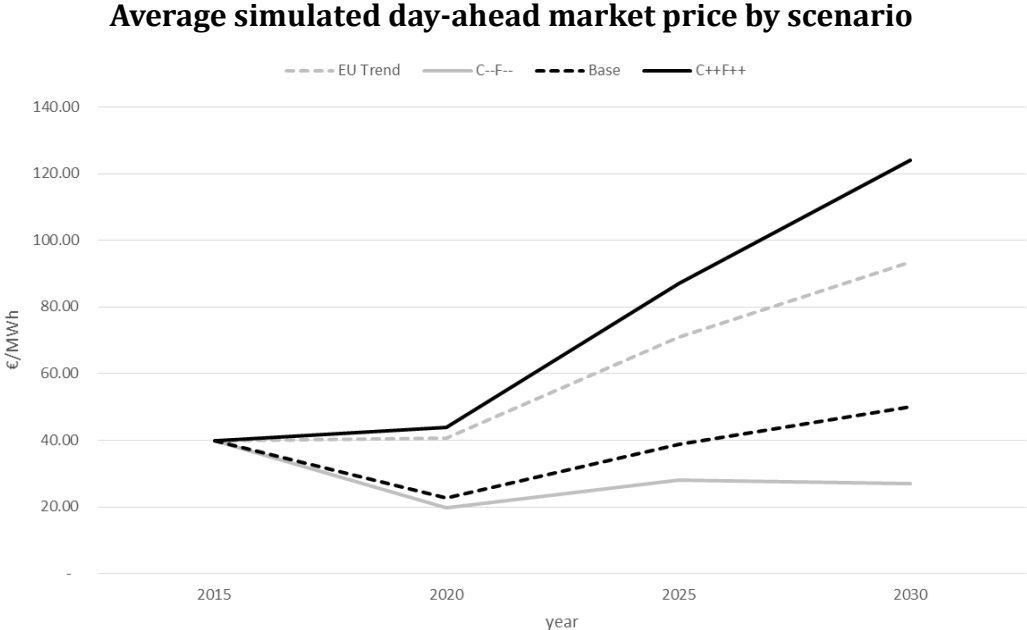

Note: These EU trend scenario is based on European Commission (2016) and does not represent an estimation of the most likely development.

The related profitability estimates for our company sample are provided in the next figure. Following the above described price dynamics, our first results show that, independently of the scenario, Swiss hydropower continues generating losses in 2020 on average (red marked cases). From 2020 onwards the **profit situation strongly depends on the underlying price pathway**. In 2025 (blue marked case) and 2030 (green marked case) the findings show that in case of the EU scenario and especially the C++F++ scenario, hydropower is on average expected to become profitable again. Contrary, under

current fuel and carbon price levels (Base scenario, quadratic marker) the profitability only gradually shifts towards the positive side with several companies still making losses in 2030. Finally, a further decline of fuel prices could prolong and aggravate the current negative income situation until 2030. The results also show a difference between the potential change in profitability for the different companies. Some show only minor changes due to the different price assumptions, whereas others exhibit huge variations. Albeit, this is partly influenced by the simplified model structure of Swissmod compared to real world conditions, it again showcases the heterogeneity in the profitability of Swiss hydropower.

**Profits in million CHF using financial costs**

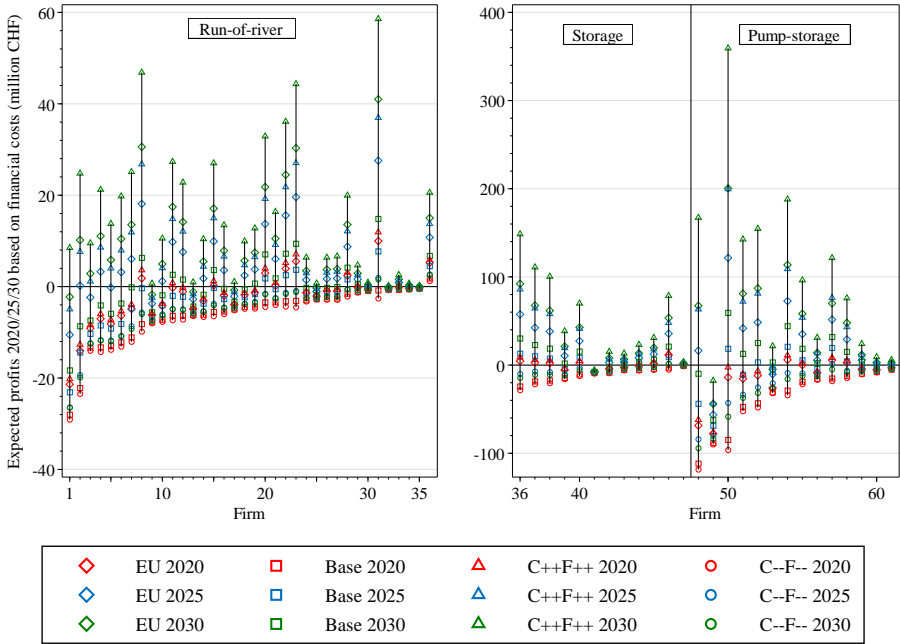

Summarizing, the estimates for future profitability show a large *dependency of Swiss hydropower on European market conditions*. As a result, the economic situation of Swiss hydropower could considerably improve in the coming decade if prices resurge, thereby reversing the current picture. However, if prices would stay at low levels, the tight economic situation observed in 2015 could persist.

**5 Impact of water fee reform proposals**

Given the challenges faced by Swiss hydropower companies, a political debate about potential remedies and counter measures has emerged in recent years. As the influence on general Continental European power market developments by Swiss companies or policy makers is limited, a reformation of the water fee framework has taken center stage in this process. The current policy debate encompasses different options how the currently fixed fees could be adjusted. Following the Swiss council, six variations are to be assessed (Bundesrat, 2018a):



- 1) Flexible water fees (with a fixed and a variable part)
- 2) Fee on the resource rent
- 3) No federal maximum of the water fee, instead qualitative guidance
- 4) Cantonal regulation only, no maximum given by federal level
- 5) Levy on consumers e.g. via network surcharge (instead of holders of the concession)
- 6) Integration in the national fiscal equalization

To provide a potential range of the influence of water fees on company profitability as a first assessment, we contrast the results presented above—based on the current level of water fees (110 CHF/kW)—with an abolishment of the current water fee regime (i.e. replacing it with other mechanisms like in Option 5, which means a fee of 0 CHF/kW).

Comparing the profitability assessment without water fees (see figure above) with the previous assessment shows the expected *general upward shift* in profits. However, it does not alter the overall

### Profits in million CHF using financial costs without water fees

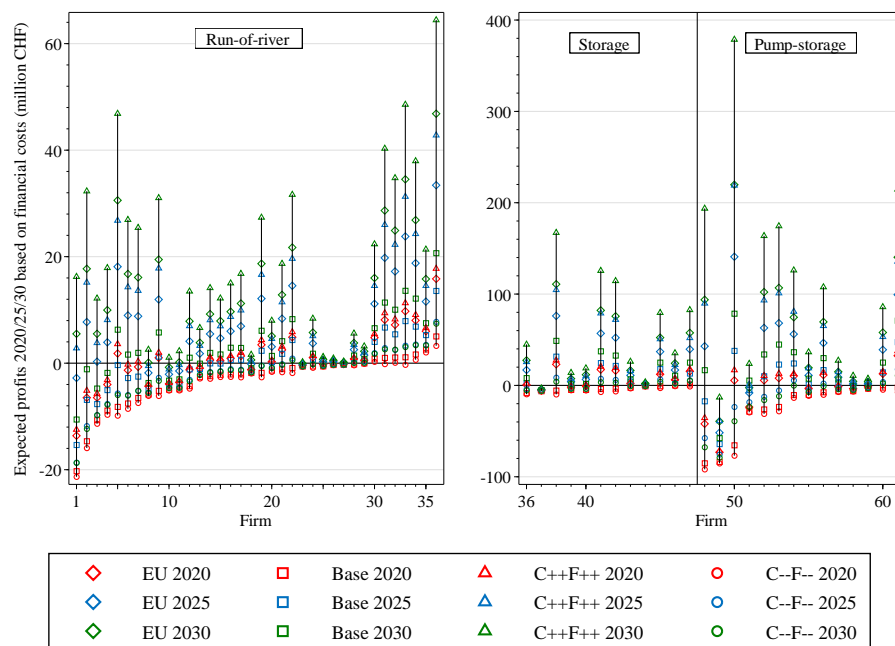

structural findings. The hypothetical setting would especially *improve the situation for companies that are close to break-even* conditions, whereas it would have little impact under favorable market conditions nor would it be sufficient for high-cost companies.

## 6 Extrapolation to overall Swiss Hydropower

The analysis so far focused on the data set of 62 hydropower companies. Albeit capturing a significant share of the overall population of Swiss hydropower stations and the majority of storage and pump-storage plants, the question of *how the company specific findings translate to the overall population of hydropower plants* remains.

Given that the company cost data and profit estimates do not provide individual station specific information, we allocate the profit information to specific station types by using the installed capacity of the company stations as weights. Aggregating these station specific profit estimates across the three technology types (run-of-river, storage, and pump storage) provides a proxy of the total profits observed in the sample for each type. These averages in turn then can be matched with the overall installed capacity for each technology, as provided by the WASTA, to derive the respective Swiss total per technology type. As we move from company types to station types the resulting totals do not entirely match with the profit numbers on company level; i.e. the profit for companies classified as ‘pump storage’ consists of their net revenues from all their stations regardless of their type, whereas the total ‘pump storage’ profit is an estimate for pump storage stations only. Given this procedure, the resulting numbers should be seen as indicative and are aimed to provide a comparison between the scenarios.

For 2015, we *estimate an overall loss* (based on the financial cost accounting approach) for the total Swiss hydropower sector that is in line with our estimates for the sample of companies and amounts to the numbers indicated in the table below.

In million CHF	Run-of-river	Storage	Pump-storage	Overall
<b>Company sample</b>	-50.4	-49.6	-56.0	-156.0
<b>Swiss hydropower populaton</b>	-113.9	-57.0	-118.4	-289.3

Due to their large share in overall production and installed capacity, the run-of-river plants account for roughly two thirds of these losses. If an imputed cost accounting is used instead of the financial cost accounting, the losses are significantly higher (see Appendix).

Compared to the total yearly budget of the market premium for hydropower (Marktprämie für Grosswasserkraftanlagen), our estimates indicate a higher need than 110 million CHF. However, given the limitations of the extrapolation and the general exclusion of other market revenue options like intra-day and system service markets, the presented numbers are likely to overestimate real world losses. For a final conclusion on whether the premium is sufficient to compensate company losses, a more extensive assessment of the underlying company opportunities would be needed. Furthermore, as the company assessment is performed on level of the ‘Partnerwerke’, financial relations on the level of energy companies could further alter the picture.

Compared to the overall water fee amount paid by Swiss hydropower companies of 544 million CHF (Bundesrat, 2018a), the estimated total loss in 2015 is significantly lower. Consequently, one could argue that an adjustment of the water fee regime is sufficient to provide a remedy. While we have already shown that this does not necessarily hold for all companies due to the large inherent heterogeneity in profitability in the sample, the question remains *how future revenue prospects compare to the water fee charges*.

In what follows, we use the future scenarios presented above and similarly extrapolate the company numbers to overall Swiss estimates for two cases, i.e. a case with the current water fee level (110 CHF/kW) and the hypothetical case of an alternate refinancing option (0 CHF/kW). The resulting profit estimates for the Swiss hydropower population (based on the financial cost accounting approach) is assessed in the table below.

In million CHF	110 CHF/kW water fee				0 CHF/kW water fee			
	RoR	Storage	Pump	Overall	RoR	Storage	Pump	Overall
<i>EU 2020</i>	-315.9	-317.3	-331.8	-965.0	-63.3	-102.7	-234.3	-400.4
<i>EU 2025</i>	249.8	424.9	-24.9	649.8	502.4	639.5	72.6	1214.5
<i>EU 2030</i>	670.2	882.0	157.8	1710.0	922.7	1096.5	255.3	2274.6
<i>C++F++ 2020</i>	-257.5	-257.6	-309.3	-824.5	-5.0	-43.0	-211.9	-259.8
<i>C++F++ 2025</i>	548.2	833.8	145.5	1527.5	800.8	1048.4	243.0	2092.2
<i>C++F++ 2030</i>	1243.3	1711.1	526.9	3481.3	1495.9	1925.6	624.4	4046.0
<i>C--F-- 2020</i>	-709.0	-768.4	-507.3	-1984.7	-456.4	-553.9	-409.8	-1420.0
<i>C--F-- 2025</i>	-555.9	-493.0	-377.4	-1426.2	-303.3	-278.4	-279.9	-861.6
<i>C--F-- 2030</i>	-570.1	-564.9	-418.0	-1553.0	-317.5	-350.4	-320.5	-988.4

These explorative results highlight two main aspects. First, the general direction of profitability (i.e. net-loss or net-profit) is mostly not impacted by water fees in our scenario sample. While specific companies may benefit from the cost reduction, we do not overserve a general switch. This is largely influenced by the second aspect of the market dynamics: *the absolute scale of losses and profits can easily exceed the total water fee volume*. The high (C++F++) and low (C--F--) profit numbers show a range of several billion CHF. In case of unfavorable market conditions, losses easily could amount to numbers such that even a complete abolishment of water fees would not shift the picture. In favorable market conditions, on the other side, revenues could take on such high values that water fees would not pose a threat to profitability. Consequently, an adjustment of water fees is likely to be helpful for companies to cope with challenging market conditions only if the break-even point is within reach.

Summarizing, our estimates for the overall Swiss hydropower sector and the impact of water fees on profitability mirror the findings made on the level of the sampled companies in that there is a large variability in profitability and dependence on European market conditions. An adjustment of water fees is likely to play a decisive role in tight cost-profit settings.

## 7 Financial flows: Water fees and fiscal equalization

After examining the cost and profitability related aspects of water fees, we now turn to the second important side: the monetary flows associated with the fees. As a first step and to provide context to the overall financial flows between cantons in Switzerland, we compare water fees with flows from the national fiscal equalization system. Given substantial changes in the ownership structure between 2015 and 2016, the subsequent analysis is based on data from 2016. In that year, the total amount of *water fees* received by all 26 cantons was approximately 544 million CHF (Bundesrat, 2018a). The cantons Valais and Grisons (VS and GR) received about 50% of this amount; Ticino, Aargau, Bern and Uri (TI, AG, BE, UR) about 32% (highlighted in dark blue in the figure below).

The *national fiscal equalization system* aims to mitigate the differences between cantons in terms of their financial capacity and cost burden (see Federal Council, 2018). The latter consists of two components: i) resource equalization, and ii) cost compensation.<sup>2</sup> The former divides the cantons into financially strong cantons that pay into the resource equalization scheme, and financially weak recipients (Bundesrat, 2018b). In 2016, the group of financially strong, i.e. “paying” cantons consisted of seven cantons (BS, GE, NW, SZ, VD, ZG and ZH), while the remaining 19 cantons built the group of “receiving cantons” (EFV, 2015, marked in red and green in the figure below).

### Overview of financial flows (2016)

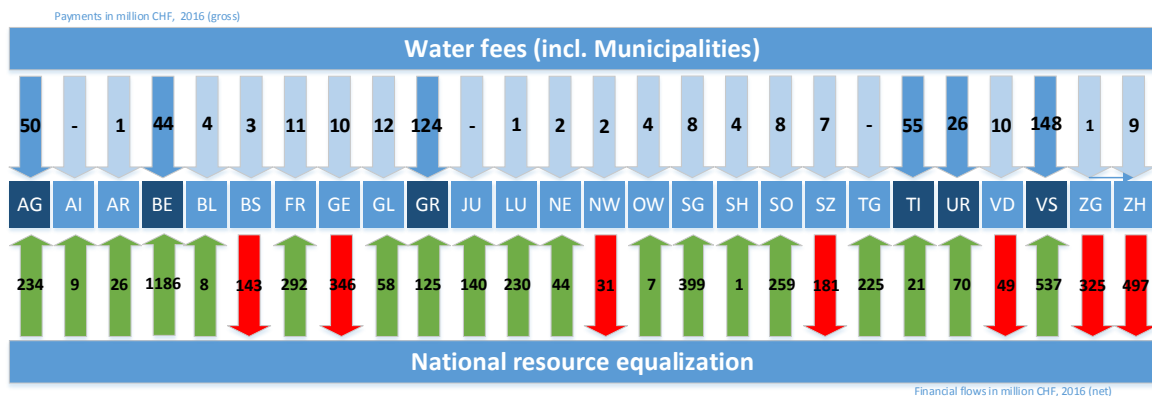

The revenue generated from water fees as presented in the figure above is based on an estimation by the Swiss Federal Office for Energy (SFOE) for the year 2016 (Bundesrat, 2018a). Contrary to the financial equalization system, this overview only provides the ‘inflow’ of water fee payments to cantons but does not capture the ‘payments’ done via cantonal owned hydropower plants. To obtain those values, the overall structure regarding utility ownership and thus hydropower plant control needs to be taken into account.

<sup>2</sup> The model contains also a cohesion fund, which provides extra funding based on systemic changes due to the change in the model of 2008. However, the cohesion fund has little relevance for the subject at hand and is thus excluded in this analysis.

## 8 Financial flows: The example of Zurich and Grison

To get an impression of the relations embedded in the water fee framework we investigated, as an illustrative case, the *flows of water fee payments between entities* in the cantons of Grison and Zurich as well as the city of Zurich. For this we need to disentangle the flows to Grison to individual plants and identify the owners of those plants.

Based on the yearly energy production of all hydropower plants located in Grisons (taken from WASTA) multiplied with the cost generated by water fees as estimated by the utilities (based on SFOE, 2018, p.22, with a value of 0.0145 CHF/kWh for 2016), we obtain a total value of approximately 116 million CHF for the year 2016. This is slightly less than the 124 million CHF estimated by the SFOE (see previous section).

In the next step, the water fees payed by individual hydropower plants are “attributed” to the owners of the plants, according to their shares hold in the respective companies. The identification of ownership is highly complex, due to the complicated shareholder structure of many Swiss hydropower plants; i.e., the plants listed in WASTA can have as much as eight different owners. The shareholders can either be public entities (cantons or municipalities) or other utilities, which in turn have their own ownership structure.<sup>3</sup> Breaking down the different shareholder structures allows us to display financial flows from one public entity, as a direct or indirect shareholder of one or many utilities, to another public entity as the recipient of water fee payments.

The figure on the next page shows a simplified model of the relation of shares and financial flows between utilities and public entities in Zurich and Grisons. Besides cantonal and municipal entities, various utilities are major players in the energy market in Grisons. The most relevant of them are the Utility of the Canton of Zurich (Elektrizitätswerke des Kantons Zürich EKZ), Utility of the City of Zurich (Elektrizitätswerk der Stadt Zürich EWZ), Axpo Holding AG (including CKW)<sup>4</sup>, Repower AG, and Kraftwerke Hinterrhein AG.

The black arrows represent the percentages of shares and show, which entities have full or partial control of power plants located in the canton of Grisons. The green arrows represent the financial flows in terms of water fee payments attributable to direct and indirect shareholdings in utilities.

The figure highlights the *complexity of the relations within the Swiss hydropower sector* and the challenges in identifying financial flow relations between the different actors.

---

<sup>3</sup> For instance, the Kraftwerke Hinterrhein AG (2018) has nine shareholders, including Axpo Power AG which is part of the Axpo Holding AG, which itself has nine shareholders of whom each is either a canton or a utility controlled by cantons (Axpo Holding AG, 2018; the shareholder of Axpo Holding AG include: Canton of Zurich with 18,342%, Elektrizitätswerke des Kantons Zürich EKZ with 18,410%, Canton of Aargau with 13,975%, AEW Energie AG with 14,026%, SAK Holding AG with 12,501%, EKT Holding AG with 12,251%, Canton of Schaffhausen with 7,875%, Canton of Glarus with 1,747% and Canton of Zug with 0,873%.

<sup>4</sup> In the case of Axpo, the Centralschweizerische Kraftwerke AG CKW is included and displayed as one party, since Axpo is the major shareholder (with 81%) of CKW.

# The cantons of Zurich and Grisons: shareholdings and financial flows in 2016

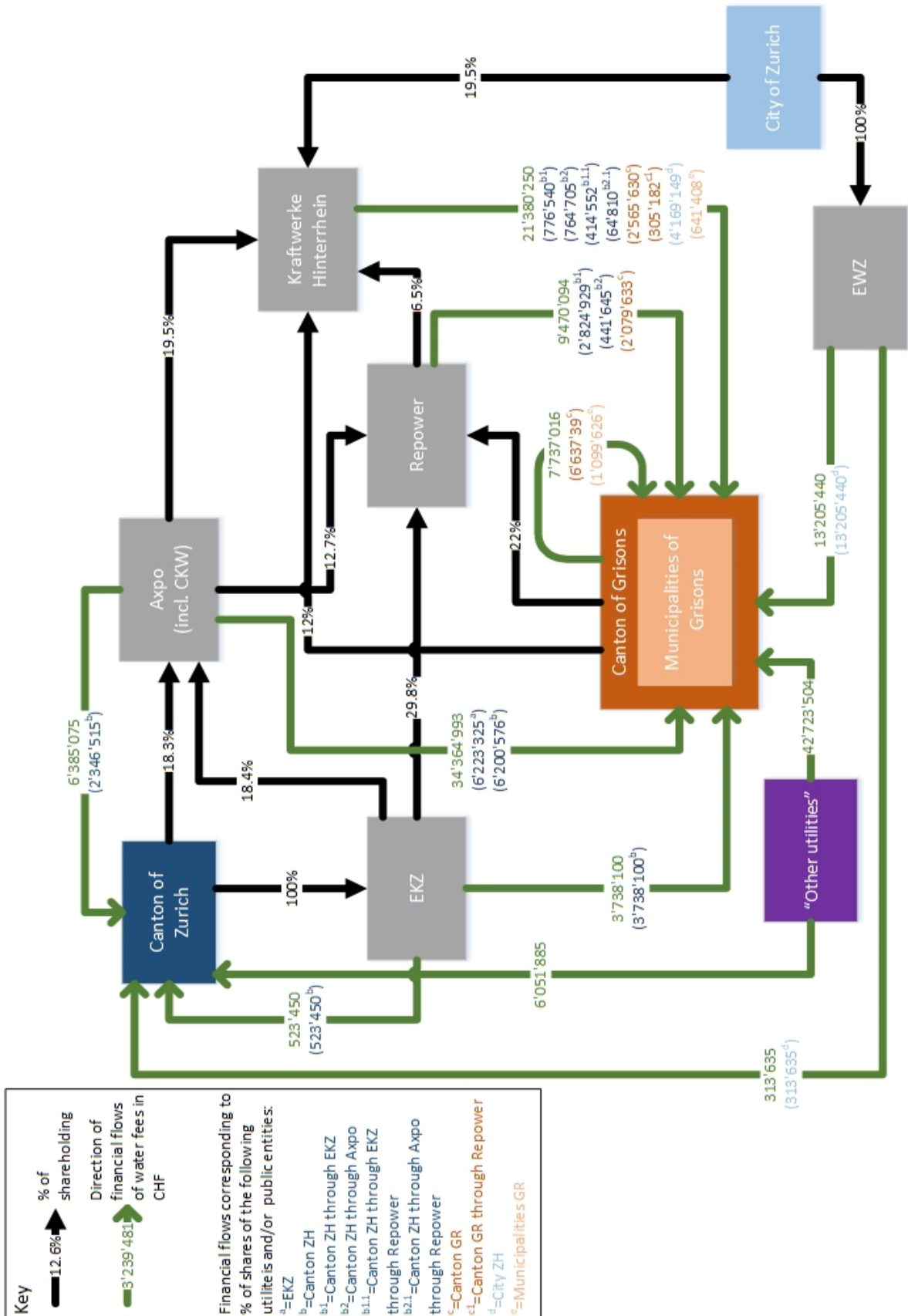

The financial flows presented in the figure above can be ordered in terms of their origin, based on the direct and indirect shareholding and thus be traced back to the respective public entities, as summarized in the table below.

<b>Public entity (year 2016)</b>	<b>Total value of attributable water fees in million CHF</b>	<b>Percentage of water fee revenues of Grisons</b>
Canton of ZH	21.440	18.4%
City of ZH	17.375	15.0%
Canton of GR	11.588	10.0%
Municipalities of GR	1.741	1.5%
“residual value”	64.109	55.2%
<b>TOTAL</b>	<b>116.252</b>	<b>100%</b>

By taking into account the shareholdings of public entities, the analysis reveals that the canton and municipalities of Grisons themselves account for approximately 11.5 % of their total attributable water fee revenue. The “residual value” consists of other public entities and utilities, which have shareholdings in utilities that control power plants in Grisons and therefore are subject to water fee payments to the canton and municipalities.

A similar pattern can be observed for the canton of Zurich:

<b>Public entity (year 2016)</b>	<b>Total value of attributable water fees in million CHF</b>	<b>Percentage of water fee revenues of Zurich</b>
Canton of ZH	2.870	31.1%
City of ZH	0.313	3.4%
“residual value”	6.052	65.5%
<b>TOTAL</b>	<b>9.235</b>	<b>100%</b>

The canton itself, through direct and indirect shareholdings accumulates approximately 31 % of the total of attributable water fee revenues. The residual value can be allocated mainly among the remaining Axpo Holding AG shareholders.

To get a full overview of financial flows induced by water fees and *to obtain a comprehensive picture*, the same *analysis needs to be extended to all 26 cantons* and subsequently be linked to the respective cantonal budget and inner cantonal financial flows. For example, for Grisons water fee revenues correspond to about 6% of the yearly cantonal budget. On municipal level however, the share of the revenue generated by water fees can amount to more than 40% of the yearly budget (SWV, 2017). Hence, changes in water fee payments will likely have significant effect on cantonal and municipal finances.

## 9 Water fees and fiscal equalization in Grisons

In the cantons of Valais and Grisons, water fees are split among the canton and those municipalities that hold the water rights according to cantonal legislation. And, in both cantons, the water fees are taken into account in the fiscal equalization scheme that aims to reduce disparities caused by two main factors: firstly, by different revenue raising or fiscal capacities (“resource potential”) and, secondly, by different costs of providing a standard set of public services due to different geographical and societal circumstances (AfG, 2016; Kanton Wallis, 2018). Hence, *changes in water fee payments will have*

- a) *a direct effect* on the financial resources available in municipalities granting hydropower concession , and
- b) through the fiscal equalization mechanisms an *indirect effect* on the financial situation in other municipalities.

As a consequence, one must expect induced impacts on public expenditure, and thus on the economic development on the cantonal and municipal level. Accordingly, to gain a deeper insight in the economic role of water fees, we investigate the above-mentioned effects in the canton of Grisons for different water fees reform options (Bundesrat, 2018a, see Section 5).

In a first step, we analyzed the impact of different water fee regimes (with lower maximum rates) on the so-called resource potential of the municipalities and on the resource equalization payments within the canton of Grisons for the reference year of 2012 which was selected to start our analysis for two reasons: First, because the data are well documented in the official report on the —at that time— proposed revision of the cantonal equalization system (Grosser Rat, 2013). It was subsequently approved by parliament, and is in force since 2016. Second, as we can only provide preliminary results at this stage of research, it is politically less sensitive than an analysis based on fiscal equalization data for 2018 or any future projections.

First results for the hypothetical fiscal equalization in 2012 are presented in the table below (the calculations are based on fiscal data and the methodology documented in Grosser Rat (2013); further details on these calculations are provided in Hediger and Herter (2018)). We use the current water fee maximum of 110 CHF/kW as reference case and investigate four scenarios with alternative maximum water fee rates at 100, 80 and 50 CHF/KW, respectively, and the hypothetical case without water fees at all.



Hypothetical case year: 2012*	<i>Reference</i>	<i>Water fee scenarios</i>			
	<b>110 CHF/kW</b>	<b>100 CHF/kW</b>	<b>80 CHF/kW</b>	<b>50 CHF/kW</b>	<b>none</b>
Change of municipal water fee receipts (Mio CHF/year):	0	-4.869	-14.607	-29.214	-53.559
Change in net resource equalization (Mio CHF/year):	0	-0.139	-0.340	-0.403	-0.626
Total change (Mio CHF/year):	0	-4.959	-14.777	-29.272	-54.185
No. of mun. paying into the cantonal resource equalization:	54	54	51	42	30
No. of mun. receiving transfers from the cantonal res. eq.:	90	90	93	102	124
No. of mun. excluded from cantonal resource equalization:	2	2	2	2	2

\*Total number of municipalities: 146 as of 01/01/2014

The results indicate that, on the municipal level, the major net financial effects of reducing the water fee maximum would be of direct nature (lower water fee receipts), while the indirect effect would be rather small. But, this would not only affect those municipalities that receive water fees, but also all the other municipalities:

- Due to the lower resource potential in the 117 water fee-receiving municipalities, the ***number of municipalities*** attributed as resource strong and therefore ***paying into the resource equalization would progressively decline with a declining water fee maximum.***
- Moreover, our calculations reveal that, irrespective of the water fee scenario, all municipalities would financially loose from this policy-induced change, also those that do not receive water fees.

Finally, the canton would lose fiscal revenue from water fees at the same amount as the sum of municipalities, as they are equally split between the canton and the concession-giving municipalities. In addition, the canton would have to cover the change in net resource equalization, as shown in the table above. Thus, the immediate financial costs in the cantonal budget would be equal to the total change in municipal finance, as shown in the table above.

Summarizing, the first assessment of the direct and indirect financial effects in Grisons shows that ***changes in the water fee system would financially affect all municipalities***, not only those directly receiving water fees, and the cantonal budget as well. This in turn raises questions on the induced effects on the regional economies and regional development. Given that the water fee examples so far only represent decreasing scenarios, the question remains how increasing water fee flows (i.e. due to variable fees in a high prices market environment) would impact the fiscal scheme.

## 10 Conclusion so far and next steps

Albeit being an interim report and relying on ongoing work and partial assessments, we can provide some first conclusions and insights for the ongoing hydropower and water fee debates:

1. **Challenging/tight market conditions:** A large share of companies makes losses or is close to break-even in our assessment of the 2015 market conditions. Albeit the assessment is limited to day-ahead energy market revenue, the results highlight the challenge hydro companies face with the current market environment. Many run-of-river companies face higher losses as the average market price is more important for them; some pump-storage companies show the lowest profitability due to the low price spread on the market and high capital costs.
2. **Large heterogeneity:** The results showcase that a general ‘one-fits-all’ conclusion is typically not feasible for the Swiss hydropower sector. The assessment shows that there remains a significant fraction of companies that are profitable even under current conditions. Similar, there is a fraction of companies with significantly higher cost that pose challenges even in more favorable market conditions. Also the role of captive customers and water fees is highly company specific.
3. **Market dynamics are important:** The chosen market development scenarios highlight the potential price range on the European market in coming years. The feedback of those developments on revenues/losses can easily be a multiple of the total water fee volume. This could be seen as reinforcing the argument that in a more volatile market framework a more flexible water fee system is advisable.
4. **Financial relation of Swiss hydropower is complicated:** The complete structure of underlying water fee flows and financial flows is difficult to disentangle and thereby the draw of a clear picture of ‘who pays/who gains’ is not straightforward. Given the interrelation of fiscal budget concerns and energy policy via the water fees a closer examination will be needed.
5. **Local impact important:** The Grison example shows that water fees have feedback effects to overall cantonal/municipal financial situation that go beyond the pure water fee payments and thereby also impact the regional economies and regional development.

As is evident from the findings so far, there are still multiple open points that need to be addressed to derive a more comprehensive assessment of the distribution aspects water fee options and the future development of Swiss hydropower in general. Within the project cluster the following steps will be taken in the coming months to complement this preliminary report and integrate the findings with the overall project cluster insights:

- Assessment of the remaining water fee options and their impact on profitability; this will likely be linked to the challenge of designing a reasonable reference price and general structure for variable fees.

- Extension of the financial assessment to further Swiss cantons.
- Extension of the Grison assessment to account for fiscal year 2018 and further water fee options, and to examine impacts on regional economies.
- Combination of profitability assessment and financial/cantonal assessment.
- Extending the scope to investments and concessions to provide an answer to the fifth and final project question: What are regional, fiscal and economic feedback effects of changes in the water fee regime?

In general, the first results indicate that due to the high heterogeneity of Swiss hydropower but also the differences in the relation between cantons, municipalities and utilities in terms of accountability and financial interdependencies, a more detailed assessment of the different effects of water fee adjustments is needed. Albeit the ongoing project will address some of those aspects and concerns, the time window up to 2024 should be utilized to provide further analyses to provide stakeholders and policy makers with a comprehensive picture and insights to derive a stable compromise on the future framework for Swiss hydropower.

## References

The project progress can be traced on the project homepage:

<https://fonew.unibas.ch/de/projects/ongoing-projects/nfp70-futurehydro/>

- AfG (2018). Finanzausgleich, Amt für Gemeinden Graubünden, Chur. Retrieved May 11, 2018, from: <https://www.gr.ch/DE/institutionen/verwaltung/dfg/afg/finanzen/Seiten/default.aspx>.
- Axpo Holding AG. (2018). Aktionäre der Axpo Holding AG. Retrieved June 30, 2018, from <https://www.axpo.com/axpo/global/de/investor-relations/aktionaere.html>
- Bundesamt für Energie [BFE/SFOE]. (2017). Statistik der Wasserkraftanlagen der Schweiz für das Jahr 2016. Bern: Bundesamt für Energie BFE.
- Bundesamt für Energie [BFE/SFOE]. (2018). Rentabilität der Schweizer Wasserkraft - Resultate einer Datenumfrage bei Betreibern von Schweizer Wasserkraftwerken im Auftrag der UREK-N. Bern: Eidgenössisches Departement für Umwelt, Verkehr, Energie und Kommunikation UVEK.
- Bundesrat. (2018a). Botschaft zur Änderung des Wasserrechtsgesetzes (provisorische Fassung). Bern: Schweizerische Eidgenossenschaft. Retrieved from <https://www.news.admin.ch/newsd/message/attachments/52433.pdf>
- Bundesrat. (2018b). Wirksamkeitsbericht 2016–2019 des Finanzausgleichs zwischen Bund und Kantonen. Bern: Schweizerische Eidgenossenschaft.
- Dümmler, P., & Rühli, L. (2018). Konzessionen bei den Konzessionen: Varianten einer Reform des Wasserzinses. Bern: Avenir Suisse.
- Eidgenössische Finanzverwaltung [EFV]. (2015). Finanzausgleich 2016 zwischen Bund und Kantonen. Bern: Eidgenössisches Finanzdepartement [EFD]. Retrieved from <http://www.news.admin.ch/NSBSubscriber/message/attachments/40272.pdf>
- Filippini, M., Geissman, T. (2014): Kostenstruktur und Kosteneffizienz der Schweizer Wasserkraft. Report commissioned by the Swiss Federal Office of Energy (SFOE). Berne: SFOE.
- Filippini, M., Geissman, T. (2018): Kostenstruktur der Schweizer Wasserkraft. Aktualisierung 2017. Report commissioned by the Swiss Federal Office of Energy (SFOE). Berne: SFOE.
- Grosser Rat (2013). Reform des Finanzausgleichs im Kanton Graubünden (FA-Reform), Botschaft der Regierung an den Grossen Rat, Heft Nr. 7/2013 – 2014. Accessible at: <https://www.gr.ch/DE/institutionen/parlament/botschaften/Seiten/Botschaften.aspx>.
- Hediger, W. & Herter, M. (2018). Hydropower – a key to sustainable regional development in the Swiss Alps. Paper prepared for the Regional Studies Association RSA Annual Conference 2018, Lugano, Switzerland (revised version forthcoming).
- Kanton Wallis (2018). Interkommunaler Finanzausgleich. Retrieved May 11, 2018, from: <https://www.vs.ch/de/web/acf/perequation-financiere-intercommunale>.
- Kraftwerke Hinterrhein AG. (2018). Partnerwerk KHR: Kraftwerke Hinterrhein AG. Retrieved June 30, 2018, from <http://www.khr.ch/ueber-uns/partnerwerk-khr.html>
- Schlecht, I., & Weigt, H. (2014). Swissmod-a model of the Swiss electricity market.
- Schweizerischer Wasserwirtschaftsverband [SWV]. (2017). Wasserzinsregelung ab 2020. Wasserzins, 107(1), 33–38.

## Appendix—Statistics using imputed costs

### Production costs 2015/16 using imputed costs

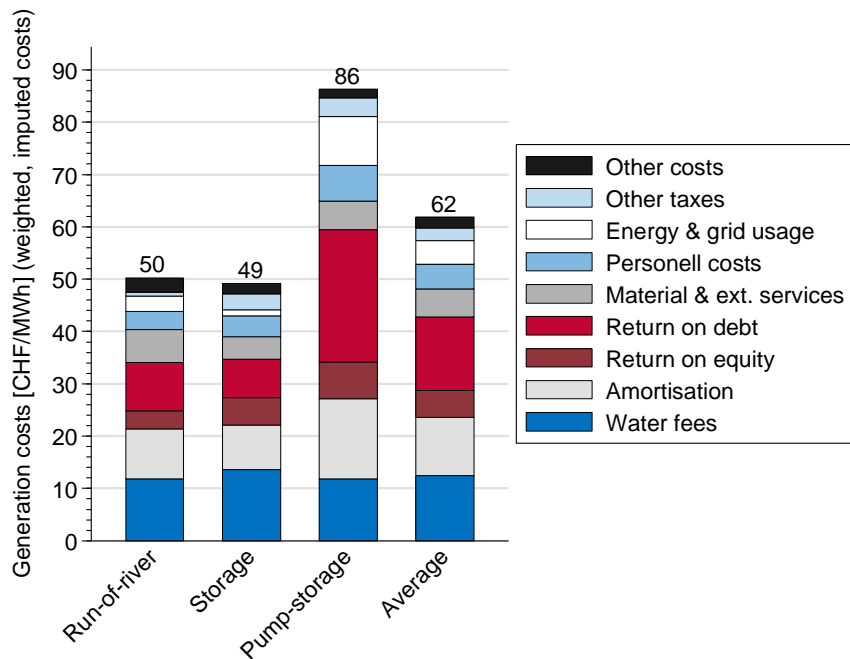

Note: These cost estimates have some limitations; i.e. they do not take into account the costs incurred by parent companies for coordinating and marketing the electricity generated since they are not listed in the business reports of a partner company.

### Profits in million CHF in 2015 using imputed costs

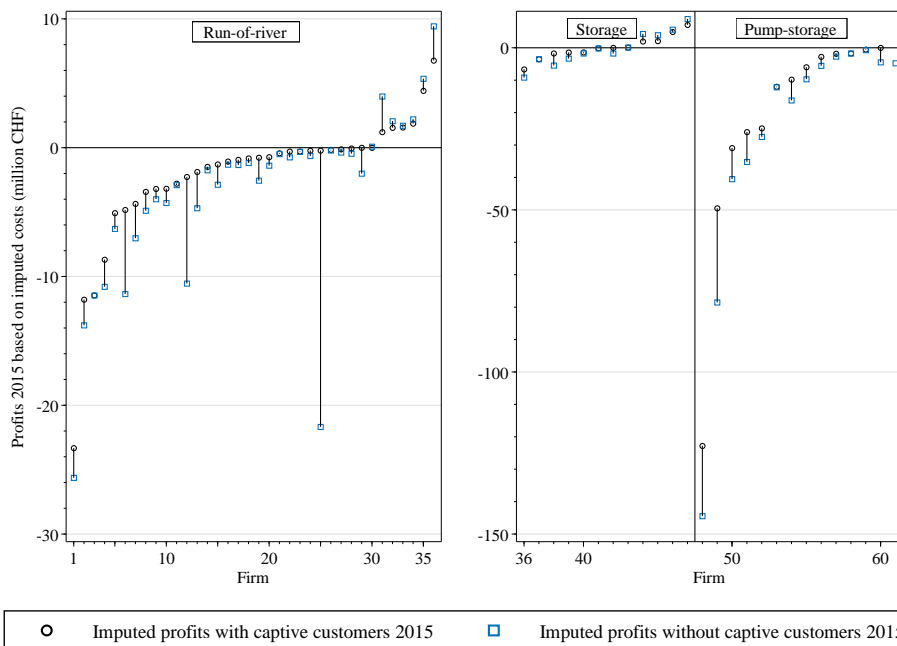

## Profits in million CHF using imputed costs

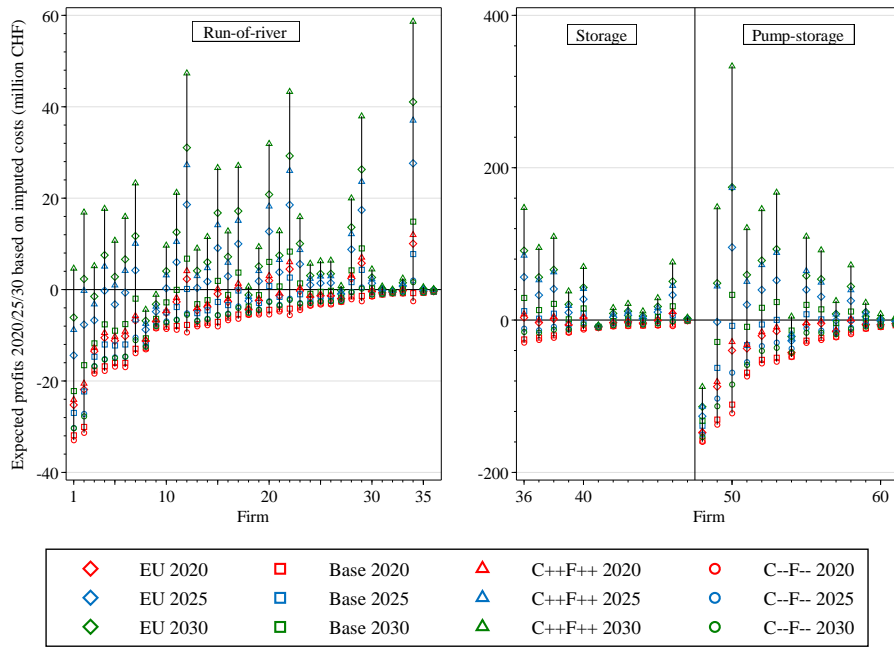

## Profits in million CHF using imputed costs without water fees

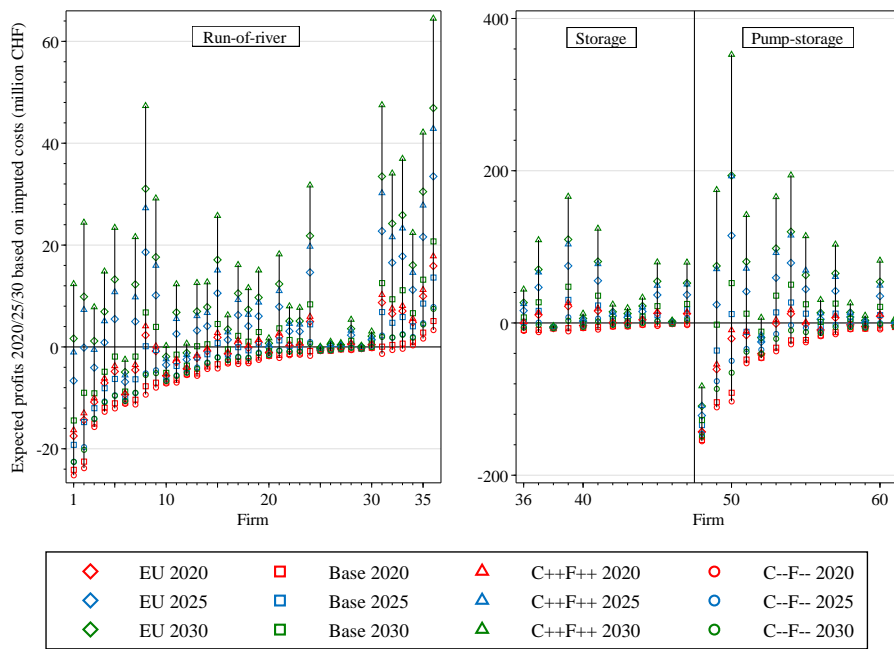

## Overall profit/loss estimates for Swiss hydropower using imputed costs

In million CHF	Run-of-river	Storage	Pump-storage	Overall
<b>Company sample</b>	-87.1	-172.9	-104.7	-364.7
<b>Swiss hydropower population</b>	-196.9	-198.4	-221.3	-616.7

In million CHF	<i>110 CHF/kW water fee</i>				<i>0 CHF/kW water fee</i>			
	RoR	Storage	Pump	Overall	RoR	Storage	Pump	Overall
<b><i>EU 2020</i></b>	-315.9	-317.3	-331.8	-965.0	-63.3	-102.7	-234.3	-400.4
<b><i>EU 2025</i></b>	249.8	424.9	-24.9	649.8	502.4	639.5	72.6	1214.5
<b><i>EU 2030</i></b>	670.2	882.0	157.8	1710.0	922.7	1096.5	255.3	2274.6
<b><i>C++F++ 2020</i></b>	-257.5	-257.6	-309.3	-824.5	-5.0	-43.0	-211.9	-259.8
<b><i>C++F++ 2025</i></b>	548.2	833.8	145.5	1527.5	800.8	1048.4	243.0	2092.2
<b><i>C++F++ 2030</i></b>	1243.3	1711.1	526.9	3481.3	1495.9	1925.6	624.4	4046.0
<b><i>C--F-- 2020</i></b>	-709.0	-768.4	-507.3	-1984.7	-456.4	-553.9	-409.8	-1420.0
<b><i>C--F-- 2025</i></b>	-555.9	-493.0	-377.4	-1426.2	-303.3	-278.4	-279.9	-861.6
<b><i>C--F-- 2030</i></b>	-570.1	-564.9	-418.0	-1553.0	-317.5	-350.4	-320.5	-988.4